

产品描述:

TRM156C1S1 是一款 600V/15A 三相全桥智能功率模块，内置低损耗沟槽栅场截止型 IGBT 和 FRD,内部集成了自举二极管 BSD,简化了客户 PCB 设计。内部集成多种保护功能，包含了欠压、短路、过温保护。并兼容 3.3V, 5V 和 15V 逻辑电平。主要用于变频驱动，如空调压缩机、小功率变频器等。

Description

TRM156C1S1 is a 600V/15A three-phase full bridge intelligent power module with built-in low power loss trench gate field-stop IGBT and FRD, The bootstrap diode BSD is integrated inside, which simplifies PCB design. Internal integration of a variety of protection functions, including undervoltage, short circuit, overtemperature protection. Th compatible with 3.3V, 5V, and 15V logic input. Mainly used for frequency conversion drive, such as air conditioning compressor, low power inverter, etc.

主要特点:

- 600V/15A 三相全桥智能功率模块
- 内置低损耗沟道栅-场截止型 IGBT
- 下桥臂 IGBT 发射极输出
- 内置带限流电阻的自举二极管 BSD
- 兼容 3.3V, 5V 和 15V 逻辑电平
- UVLO 欠压保护，过流保护，过温保护

应用:

- 变频空调压缩机
- 小功率变频器
- 电机驱动器

APPLICATION

- inverter air-conditioning compressor
- Industrial Motor
- Motor driver

MAIN FUNCTION AND RATING

- 600V/15A three-phase full bridge intelligent power module
- Built-in Lower power loss trench gate field-stop IGBT
- N-side IGBT open emitter
- Built-in bootstrap diode with current limiting resistor
- Compatible with 3.3V, 5V, and 15V logic input
- UVLO under voltage protection, short circuit protection, Over-temperature protection



封装/Package: DIP27

订货信息 PART ORDING TABLE

订货信息 Booking information	产品名称 Product name	封装形式 Package	无卤素 Halogen Free	包装方式 Packing
TRM156C1S1	TRM156C1S1	DIP27	是 Yes	条管 Tube

管脚说明/ Pin Configuration



图 1: 引脚定义图 (顶视图)

Fig1: Pin Configuration (Top View)

管脚定义/Pin Descriptions

管脚编号 Pin Number	管脚名称 Pin Name	管脚描述 Pin Description
1	V _{CC(L)}	低侧 IGBT 栅极驱动 IC 电源电压 Low-Side Common Bias Voltage for IC and IGBTs Driving
2	COM	电源公共地 Common Supply Ground
3	IN _(UL)	低侧 U 相信号输入 Signal Input for Low-Side U-Phase
4	IN _(VL)	低侧 V 相信号输入 Signal Input for Low-Side V-Phase
5	IN _(WL)	低侧 W 相信号输入 Signal Input for Low-Side W-Phase

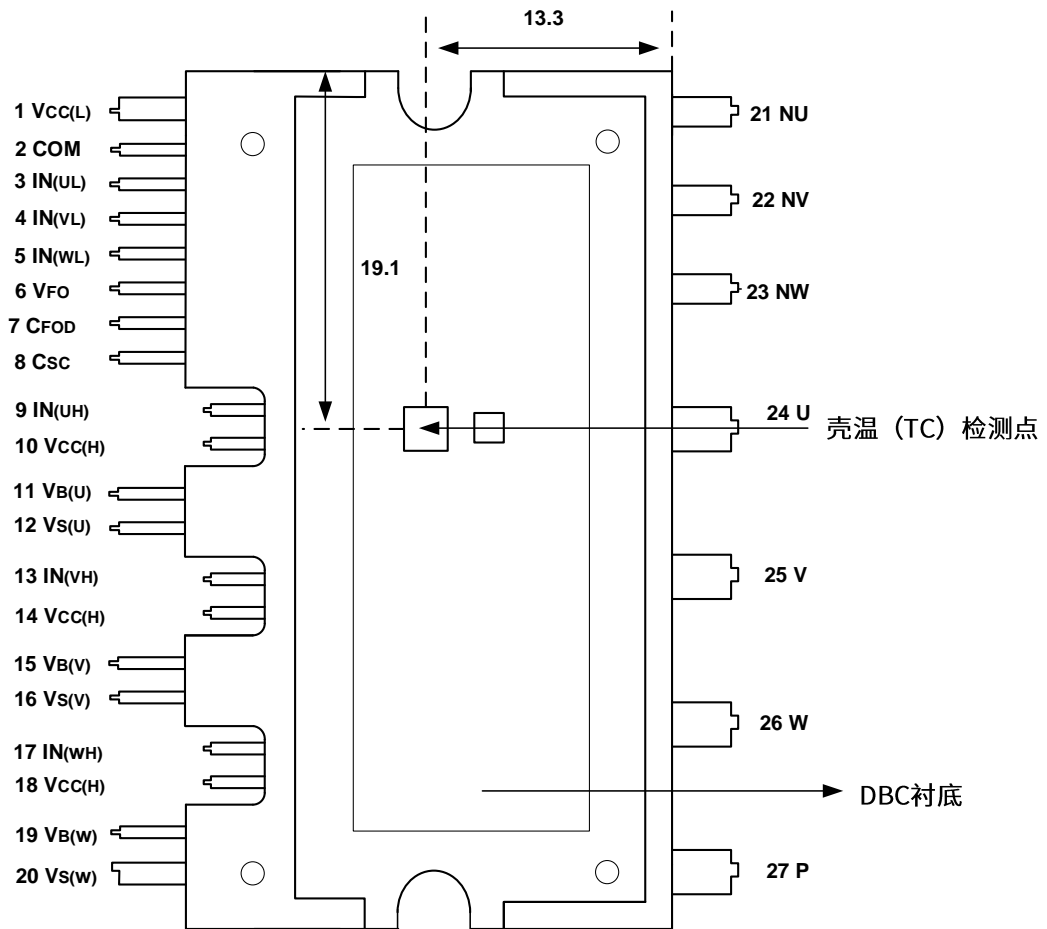
6	V_{FO}	故障输出 Fault Output
7	C_{FOD}	接电容，调整故障输出持续时间 Capacitor for Fault Output Duration Selection
8	C_{SC}	短路电流检测输入 Shut Down Input for Short-Circuit Current Detection Input
9	$IN_{(UH)}$	高侧 U 相信号输入 Signal Input for High-Side U-Phase
10	$V_{CC(H)}$	高侧 IGBT 栅极驱动 IC 电源电压 High-Side Common Bias Voltage for IC and IGBTs Driving
11	$V_{B(U)}$	U 相高侧 IGBT 栅极驱动供电电压 High-Side Bias Voltage for U-Phase IGBT Driving
12	$V_{S(U)}$	U 相高侧 IGBT 栅极驱动供电地 High-Side Bias Voltage Ground for U-Phase IGBT Driving
13	$IN_{(VH)}$	高侧 V 相信号输入 Signal Input for High-Side V-Phase
14	$V_{CC(H)}$	高侧 IGBT 栅极驱动 IC 电源电压 High-Side Common Bias Voltage for IC and IGBTs Driving
15	$V_{B(V)}$	V 相高侧 IGBT 栅极驱动供电电压 High-Side Bias Voltage for V-Phase IGBT Driving
16	$V_{S(V)}$	V 相高侧 IGBT 栅极驱动供电地 High-Side Bias Voltage Ground for V Phase IGBT Driving
17	$IN_{(WH)}$	高侧 W 相信号输入 Signal Input for High-Side W-Phase
18	$V_{CC(H)}$	高侧 IGBT 栅极驱动 IC 电源电压 High-Side Common Bias Voltage for IC and IGBTs Driving
19	$V_{B(W)}$	W 相高侧 IGBT 栅极驱动供电电压 High-Side Bias Voltage for W-Phase IGBT Driving
20	$V_{S(W)}$	W 相高侧 IGBT 栅极驱动供电地 High-Side Bias Voltage Ground for W-Phase IGBT Driving
21	N_U	U 相直流负端 Negative DC-Link Input for U-Phase
22	N_V	V 相直流负端 Negative DC-Link Input for V-Phase
23	N_W	W 相直流负端 Negative DC-Link Input for W-Phase
24	U	U 相输出 Output for U-Phase
25	V	V 相输出 Output for V-Phase

26	W	W 相输出 Output for W-Phase
27	P	直流正端 Positive DC-Link Input

内部等效电路/ Internal Equivalent Circuit



图 2：内部框图

Fig2: Internal Block Diagram

最大额定值 (T_j= 25°C, 除非特殊说明)

Absolute Maximum Ratings (T_j= 25°C, unless otherwise noted)

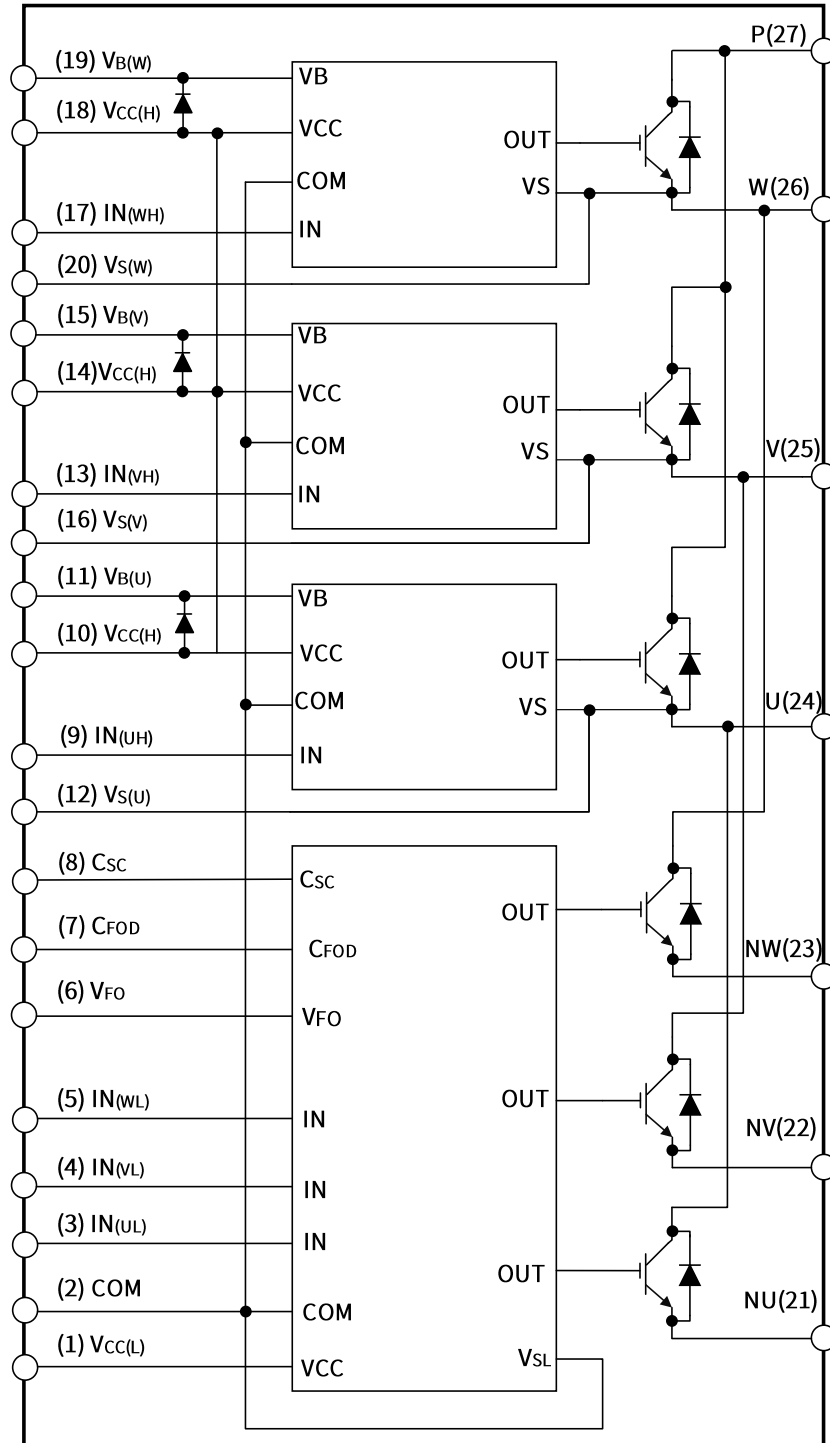
逆变部分/Inverter Part

符号 Symbol	参数 Parameter	条件 Condition	额定值 Ratings	单位 Unit
V _{PN}	电源电压 Supply voltage	应用于P-N _U , N _V , N _W 之间 Applied between P-N _U ,N _V ,N _W	450	V
V _{PN (Surge)}	电源电压 (含浪涌) Supply voltage(surge)	应用于P-N _U , N _V , N _W 之间 Applied between P-N _U ,N _V ,N _W	500	V
V _{CES}	集电极-发射极间电压 Collector-emitter voltage		600	V
± I _c	集电极电流 Each IGBT collector current	T _c = 25°C	15	A
± I _{CP}	集电极电流 (峰值) Each IGBT collector current (peak)	T _c = 25°C, T _j ≤ 150°C, 脉冲宽度小于1ms T _c = 25°C, T _j ≤ 150°C, Under 1 ms Pulse Width	30	A
P _c	集电极功耗 Collector power loss	T _c = 25°C, 单晶片 T _c = 25°C, single chip	62	W
T _j	结温 Junction temperature		-40~+150	°C

控制部分/Control Part

符号 Symbol	参数 Parameter	条件 Condition	额定值 Ratings	单位 Unit
V _{cc}	控制电源电压 Control Supply Voltage	应用于V _{CC(H)} , V _{CC(L)} —COM之间 Applied between V _{CC(H)} , V _{CC(L)} —COM	20	V
V _{BS}	高侧控制电压 High—Side Control Bias Voltage	应用于V _{B(U)} —V _{S(U)} , V _{B(V)} —V _{S(V)} , V _{B(W)} —V _{S(W)} 之间 Applied between V _{B(U)} —V _{S(U)} , V _{B(V)} —V _{S(V)} , V _{B(W)} —V _{S(W)}	20	V

V_{IN}	输入信号电压 Input voltage	应用于 $IN_{(UH)}, IN_{(VH)}, IN_{(WH)}, IN_{(UL)}, IN_{(VL)}, IN_{(WL)} - COM$ Applied between $IN_{(UH)}, IN_{(VH)}, IN_{(WH)}, IN_{(UL)}, IN_{(VL)}, IN_{(WL)} - COM$	$-0.3 \sim V_{CC} + 0.3$	V
V_{FO}	故障输出电压 Fault output supply voltage	应用于 $V_{FO} - COM$ 之间 Applied between $V_{FO} - COM$	$-0.3 \sim V_{CC} + 0.3$	V
I_{FO}	故障输出电流 Fault output current	Fo端子灌入电流值 Sink Current at V_{FO} pin	5	mA
V_{SC}	电流检测端输入电压 Current sensing input voltage	应用于 $C_{SC} - COM$ 之间 Applied between $C_{SC} - COM$	$-0.3 \sim V_D + 0.3$	V

自举二极管部分/Bootstrap Diode Part

符号 Symbol	参数 Parameter	条件 Condition	额定值 Ratings	单位 Unit
V_{RRM}	最大重复反向电压 Maximum Repetitive Reverse Voltage		600	V
I_F	正向电流 Forward Current	$T_C = 25^\circ C, T_j \leq 150^\circ C$	1	A
I_{FP}	正向电流 (峰值) Forward Current (Peak)	$T_C = 25^\circ C, T_j \leq 150^\circ C$, 脉宽小于1ms $T_C = 25^\circ C, T_j \leq 150^\circ C$, Under 1 ms Pulse Width	2	A
T_J	结温 Operating Junction Temperature		$-40 \sim +125$	$^\circ C$

系统/Total System

符号 Symbol	参数 Parameter	条件 Condition	额定值 Ratings	单位 Unit
$V_{PN(Prot)}$	自保护电源电压限制 (短路保护能力) Self Protection Supply Voltage Limit (Short-Circuit Protection Capability)	$V_{CC} = V_{BS} = 13.5 \sim 16.5V, T_j = 150^\circ C$, 无重复, 时间小于 2us $V_{CC} = V_{BS} = 13.5 \sim 16.5V, T_j = 150^\circ C$, Non-repetitive, less than 2us	400	V

T_c	正常工作壳温 Module case operation temperature	See Figure 1	-40~+125	°C
T_{STG}	存储温度 Storage temperature		-40~+125	°C
V_{ISO}	绝缘耐压 Isolation voltage	60Hz, AC 1分钟, 在插脚和散热片之间 60 Hz, Sinusoidal, AC 1 Minute, Connection Pins to Heat Sink Plate	2500	Vrms

热阻/Thermal Resistance

符号 Symbol	参数 Parameter	条件 Condition	额定值 Ratings	单位 Unit
$R_{th(j-c)Q}$	结点到壳的热阻 Junction to case thermal resistance	逆变器IGBT部分(每1/6模块) Inverter IGBT part, (Per 1 / 6 Module)	2.02	°C/W
$R_{th(j-c)F}$		逆变器FRD部分(每1/6模块) Inverter FRD part, (Per 1 / 6 Module)	3.15	°C/W

电气特性: ($T_j = 25^\circ\text{C}$, 除非特殊说明)

Electrical Characteristics: ($T_j = 25^\circ\text{C}$, unless otherwise noted)

逆变部分/Inverter Part

符号 Symbol	项目 Parameter	条件 Condition	最小值 Min.	典型值 Typ.	最大值 Max.	单位 Unit
$V_{CE(SAT)}$	集电极与发射极间饱和电压 Collector-emitter saturation voltage	$V_{CC} = V_{BS} = 15\text{V}$ $V_{IN} = 5\text{V}, I_c = 15\text{A}, T_j = 25^\circ\text{C}$		1.93	2.10	V
V_F	FRD正向导通电压 FRD forward voltage	$V_{IN} = 0\text{V}, I_c = 15\text{A}, T_j = 25^\circ\text{C}$		1.55	2.0	V
HS	t_{ON}	$V_{PN} = 300\text{V}, V_{CC} = 15\text{V}, I_C = 15\text{A},$ $T_j = 25^\circ\text{C}, V_{IN} = 0\text{V} \leftrightarrow 5\text{V},$ Inductive load (Note 1)		670		ns
	$t_{c(ON)}$			110		ns
	t_{OFF}			800		ns
	$t_{c(OFF)}$			150		ns
	t_{rr}				170	

LS	t_{ON}	集电极到发射极漏电流 Collector-emitter cut-off current	$V_{PN} = 300\text{ V}, V_{CC} = 15\text{ V}, I_C = 15\text{ A}, T_j = 25^\circ\text{C}, V_{IN} = 0\text{ V} \leftrightarrow 5\text{ V},$ Inductive load (Note 1)		750		ns
	$t_{C(ON)}$				260		ns
	t_{OFF}				780		ns
	$t_{C(OFF)}$				160		ns
	t_{rr}				180		ns
I_{CES}			$V_{CE} = V_{CES}, T_j = 25^\circ\text{C}$			1	mA

备注 1: t_{ON} 和 t_{OFF} 包括驱动 I_C 内部传输延迟时间。 $t_{C(ON)}$ 和 $t_{C(OFF)}$ 是 IGBT 自身被内部给定门极驱动条件下的开关时间。具体请参考开关时间定义。

Note1: t_{ON} and t_{OFF} include the internal transmission delay time of the driver I_C . $t_{C(ON)}$ and $t_{C(OFF)}$ are the switching times of the IGBT itself under the internal given gate driving conditions. Please refer to switching time definition for details.

开关时间定义/Switching Time Definition



图 3: 开关时间定义

Fig 3: Switching Time Definition

控制部分 (Tj= 25°C, 除非特殊说明)

Control (Protection) Part (Tj= 25°C, unless otherwise noted)

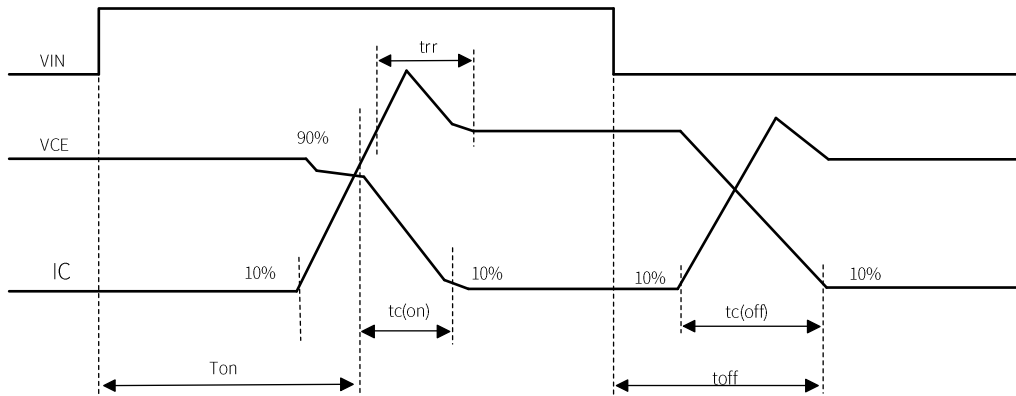
符号 Symbol	项目 Parameter	条件 Condition	最小值 Min.	典型值 Typ.	最大值 Max.	单位 Unit
I_{QCCL}	V_{CC} 静态电流	$V_{CC} = 15\text{ V}, I_{N(U,L,V,L,WL)} = 0\text{ V}, V_{CC(L)} - \text{COM}$			20	mA
I_{QCCH}	Quiescent V_{CC} Supply current	$V_{CC} = 15\text{ V}, I_{N(UH,VH,WH)} = 0\text{ V}, V_{CC(H)} - \text{COM}$			500	uA
I_{QBS}	V_{BS} 静态电流 Quiescent V_{BS} Supply current	$V_{BS} = 15\text{ V}, I_{N(UH,VH,WH)} = 0\text{ V}$ $V_{B(U)} - V_{S(U)}, V_{B(V)} - V_{S(V)}, V_{B(W)} - V_{S(W)}$			500	uA

V_{FOH}	故障输出电压 Fault Output Voltage	$V_{CC} = 15\text{ V}, V_{SC} = 0\text{ V}, V_{FO}$ 上拉4.7 K Ω 到5V $V_{CC} = 15\text{ V}, V_{SC} = 0\text{ V}, V_{FO}$ Circuit: 4.7K Ω to 5 V Pull-up	4.5			V
V_{FOL}		$V_{CC} = 15\text{ V}, V_{SC} = 0\text{ V}, V_{FO}$ 上拉4.7 K Ω 到5V $V_{CC} = 15\text{ V}, V_{SC} = 1\text{ V}, V_{FO}$ Circuit: 4.7K Ω to 5 V Pull-up			0.8	V
$V_{SC(ref)}$	短路触发电压 Short Circuit Trip Level	$V_{CC} = 15\text{ V}, C_{SC-COM}$ (Note2)	0.45	0.5	0.55	V
TSD	过温保护 Over-Temperature Protection	LVIC温度 Temperature at LVIC		150		$^{\circ}\text{C}$
ΔTSD	过温保护迟滞 Over-Temperature Protection Hysterisis	LVIC温度 Temperature at LVIC		10		$^{\circ}\text{C}$
UV_{CCD}	电源欠压保护 Control supply under-voltage protection	低侧触发电平 Detection level(L)	10.5	11.5	12.5	V
UV_{CCR}		低侧复位电平 Reset level(L)	11	12	13	V
UV_{BSD}		高侧触发电平 Detection level (H)	9.5	10.5	11.5	V
UV_{BSR}		高侧复位电平 Reset level(L)	10.5	11.5	12.5	V
V_{TS}	LVIC温度检测输出电压 LVIC Temperature Sensing Voltage Output	$V_{CC(L)} = 15\text{ V}, T_{LVIC} = 25^{\circ}\text{C}$	540	640	740	mV
t_{FOD}	故障输出脉冲宽度 Fault-Out Pulse Width	$C_{FOD} = 2\text{ nF}$ (Note3)	20			ms
$V_{IN(ON)}$	导通阈值电压 ON Threshold Voltage	应用于 $IN_{(UH, VH, WH)}, IN_{(UL, VL, WL)} - COM$ 之间 Applied between $IN_{(UH, VH, WH)}, IN_{(UL, VL, WL)} - COM$	2.8			V
$V_{IN(OFF)}$	关断阈值电压 OFF Threshold Voltage					0.9

备注 2:短路保护只对低侧有效。

Note2: Short-circuit protection is functioning only at the low-sides.

备注 3:故障脉冲的输出宽度 t_{FOD} 取决于 C_{FOD} 的值, 可采用如下公式估算: $C_{FOD} = 10^{-7} \times t_{FOD}[\text{F}]$ 。

备注 3: The fault-out pulse width t_{FOD} depends on the capacitance value of C_{FOD} according to the following approximate equation: $C_{FOD} = 10^{-7} \times t_{FOD}[\text{F}]$.

自举二极管部分/ Bootstrap Diode Part

符号 Symbol	参数 Parameter	条件 Condition	最小值 Min.	典型值 Typ.	最大值 Max.	单位 Unit
V_F	正向压降 Forward Voltage	$I_F = 0.1 \text{ A}, T_j = 25^\circ\text{C}$		2.5		V
T_{rr}	反向恢复时间 Reverse Recovery Time	$I_F = 0.1 \text{ A}, T_j = 25^\circ\text{C}$		80		ns

推荐工作条件/Recommended Operation Conditions

符号 Symbol	项目 Parameter	条件 Parameter	最小值 Min.	典型值 Min.	最大值 Max	单位 Unit
V_{PN}	电源电压 Supply voltage	应用于P – NU, NV, NW之间 Applied between P – NU, NV, NW	0	300	400	V
V_{CC}	控制电源电压 Control supply voltage	应用于 $V_{DD(H)}, V_{DD(L)}$ – COM之间 Applied between $V_{DD(H)}, V_{DD(L)}$ – COM	13.5	15	16.5	V
V_{BS}	高侧控制电源电压 High – Side Bias Voltage	应用于 $V_{B(U)} – V_{S(U)}, V_{B(V)} – V_{S(V)},$ $V_{B(W)} – V_{S(W)}$ 之间 Applied between $V_{B(U)} – V_{S(U)},$ $V_{B(V)} – V_{S(V)}, V_{B(W)} – V_{S(W)}$	13.5	15	18.5	V
T_{dead}	死区时间 Dead time	各相输入信号, $T_c \leq 100^\circ\text{C}$ For each input signal, $T_c \leq 100^\circ\text{C}$	2			us
dv_{CC}/dt dV_{BS}/d	控制电源纹波 Control supply variation		-1		1	V/us
f_{PWM}	PWM 频率 PWM input frequency	$-20^\circ\text{C} \leq T_c \leq +125^\circ\text{C}$ $-40^\circ\text{C} \leq T_j \leq +150^\circ\text{C}$			20	kHz
PWM(ON/OFF)	最小输入信号脉冲宽度 Minimum input pulse width		2.0			us
			2.0			us
V_{NC}	VNC variation	NU, NV, NW-COM之间 Between NU, NV, NW-COM (including surge)	-5		5	V

机械特性/Mechanical Characteristics And Ratings

参数 Parameter	条件 Conditions	最小值 Min.	典型值 Typ.	最大值 Max.	单位 Unit
安装扭矩 Mounting torque	螺丝钉尺寸: M3 Mounting screw: M3	0.6	0.7	0.8	N·m
设计平面度 Heat-sink flatness	(备注4) (Note4)	0		+150	um
重量 Weight			15		g

备注 4: 散热部分平整度的测量位置如下

Note4: Measurement positions of heat radiation part flatness are as below

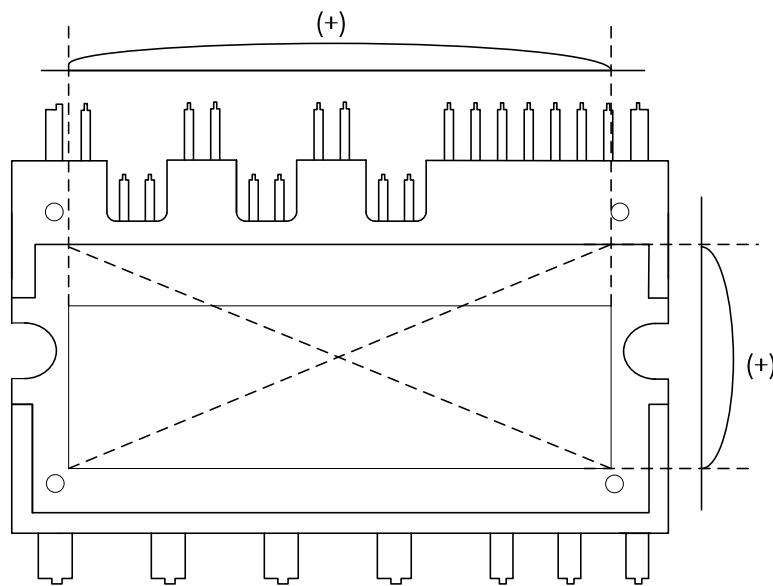

应用指南 Application Guide

欠压保护/Under-Voltage Protection



图 4: 欠压保护时序图 (低侧)

Fig 4: Under-voltage protection timing charts (Low-side)

a1: 电源电压上升: 电压上升到 U_{VCCR} , 电路在下一个输入脉冲来临的时候开始动作。

a1: Control supply voltage rises: after the voltage rises U_{VCCR} , the circuits start to operate when next input is applied.

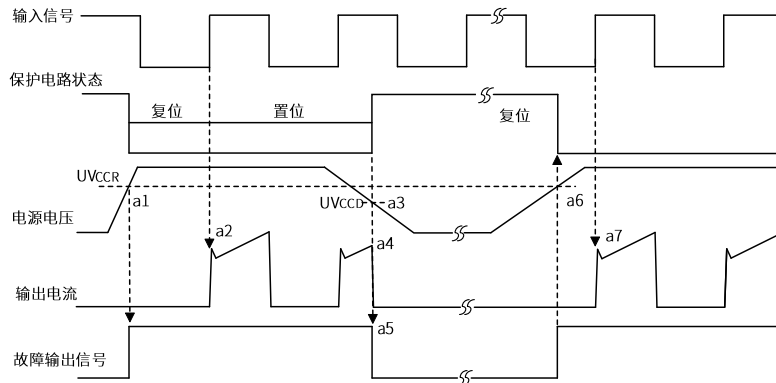
a2: 正常运行: IGBT 开启并加载电流。

a2: Normal operation: IGBT ON and carrying current.

a3: 欠压检测点(U_{VCCD})。

a3: Under-voltage detection (U_{VCCD})

a4: 不管输入是什么信号, 所有低侧 IGBT 都是关闭状态。

a4: IGBT OFF in spite of control input condition.

a5: 开始输出一个固定脉宽的故障信号。

a5: Fault output operation starts with a fixed pulse width.

a6: 欠压恢复(U_{VCCR})。

a6: Under-voltage reset (U_{VCCR}).

a7: 正常运行: 当下一个输入信号从低到高的时候, IGBT 导通并加载负载电流。

a7: Normal operation: IGBT ON and carrying current by triggering next signal from LOW to HIGH.



图 5: 欠压保护时序图 (高侧)

Fig 5: Under-voltage protection timing charts (High-side)

- b1: 电源电压上升: 电压上升到 UV_{BSR} , 电路在下一个输入脉冲来临的时候开始动作。
 b1.: Control supply voltage rises: after the voltage reaches UV_{BSR} , the circuits start to operate when next input is applied.
- b2: 正常运行: IGBT 导通并加载。
 b2: Normal operation: IGBT ON and carrying current.
- b3: 欠压检测 (UV_{BSD})。
 b3: Under voltage detection (UV_{BSD}).
- b4: 不管输入是什么信号, IGBT 都是关闭状态。但没有 F_o 信号输出。
 b4: IGBT OFF in spite of control input condition, but there is no fault output signal.
- b5: 欠压恢复(UV_{BSR})。
 b5: Under-voltage reset (UV_{BSR}).
- b6: 正常运行:当下一个输入信号从低到高的时候, IGBT 导通并加载负载电流。
 b6: Normal operation: IGBT ON and carrying current by triggering next signal from LOW to HIGH.

短路保护/Short Circuit Protection

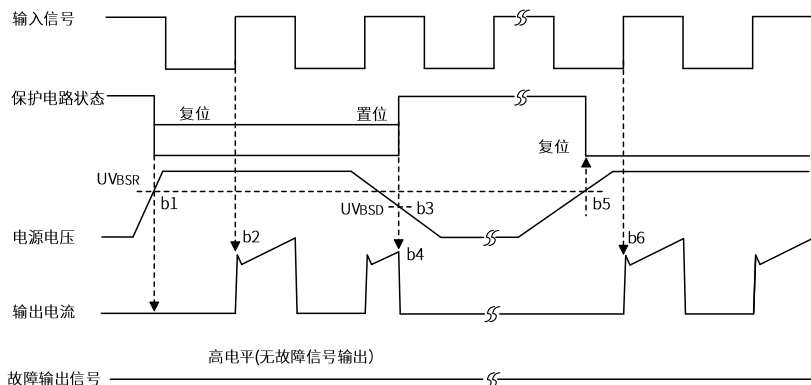

图 6: 短路电流保护时序图

Fig6: Short circuit protection timing charts

- c1: 正常运行: IGBT 导通载流。
 c1: Normal operation: IGBT ON and carrying current.
- c2: 短路电流检测(Cin 短路触发)。
 c2: Short circuit current detection (SC trigger)
- c3: 所有 N 侧 IGBT 栅极被强制关断。
 c3: All N-side IGBT's gates are hard interrupted .
- c4: 所有 N 侧 IGBT 被关断。
 c4: all N-side IGBTs turn OFF.
- c5: 故障输出脚输出一个固定的脉宽信号 ($t_{Fo} \geq 80\mu s$)。

- c5: The fault output pin outputs a fixed pulse width signal($t_{Fo} \geq 80\mu s$)
- c6: 输入“L” :IGBT 关闭。
- c6: Input “L” :IGBT OFF
- c7: 输入“H” :IGBT 开通,但在故障输出期间,IGBT 仍然是关闭状态。
- c7: Input= “H” :IGBT ON,in case of the F_o signal works, the IGBT still OFF.
- c8: 正常工作: IGBT 导通, 输出电流。
- c8: Normal operation: IGBT conduction, output current.

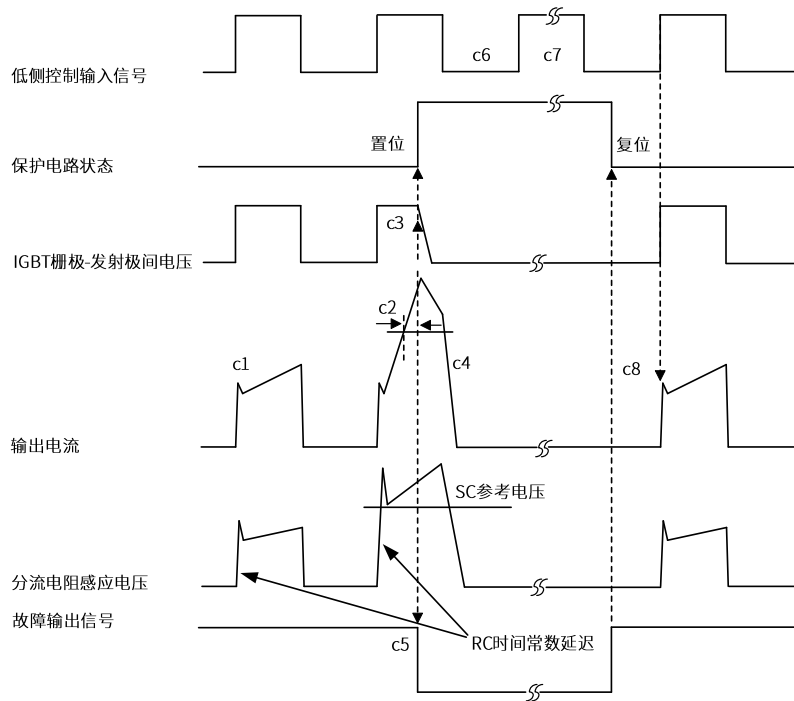
输入/输出接口电路/Input/Output Interface Circuit



图 7: MCU 输入/输出连接电路 (推荐)

Fig7: MCU I/O Interface Circuit (Recommended)

备注 5: 每个输入端子的 RC 耦合, 要根据 PWM 控制方案及其 PCB 的连线阻抗而改变。IPM 的输入端有 5K 的下拉电阻, 实际使用外部滤波电阻的时候需注意输入信号在输入端的电压降。

Note5: RC coupling at each input might change depending on the PWM control scheme used in the application and the wiring impedance of the application's printed circuit board. The input signal section of the Motion product integrates 5K (typ.) pull-down resistor. Therefore, when using an external filtering resistor, please pay attention to the signal voltage drop at input termina.

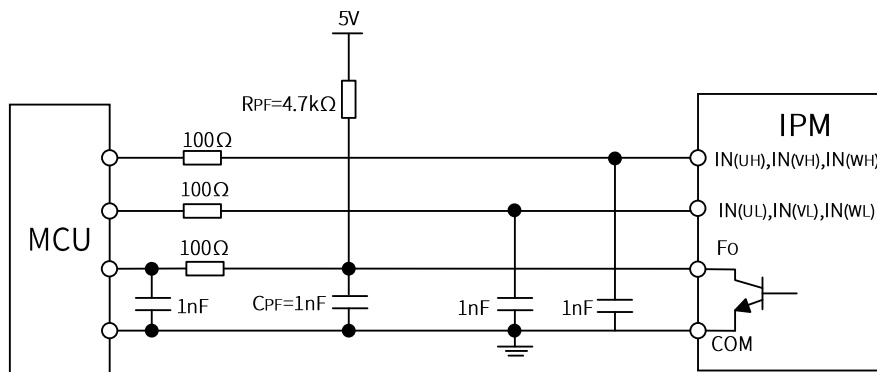
典型应用电路图/Typical Application Circuit



图 8: 典型应用电路

Fig8: Typical Application Circuit

备注/Note

1. 为了避免误动作，每一路输入引线应尽量短（小于 2-3cm）。
1.To avoid malfunction, the wiring of each input should be as short as possible (less than 2-3 cm).
2. 输入信号为高电平有效，输入信号的每一个通道都有一个 5K 的下拉电阻到地，在输入端增加 RC 滤波电路来抑制输入端引入的浪涌噪声，R1C1 的时间常数选择 50 ~ 150 ns。（推荐 R1 = 100Ω, C1 = 1 nF）。
2.Input signal is active-HIGH type. There is a 5 k resistor inside the IC to pull-down each input signal line to GND. RC coupling circuits should be adopted for the prevention of input signal oscillation. R1C1 time constant should be selected in the range 50 ~ 150 ns. (Recommended R1 = 100Ω, C1 = 1 nF).
3. A 点各接线方式的电感应尽量减小(建议小于 10nH)。使用表面贴装(SMD)型分流电阻 R4 来减小接线电感。为防止发生故障，E 点接线应尽可能靠近并联电阻 R4 的端子。
3.Each wiring pattern inductance of A point should be minimized (Recommend less than 10 nH). Use the shunt resistor R4 of surface mounted (SMD) type to reduce wiring inductance. To prevent malfunction, wiring of point E should be connected to the terminal of the shunt resistor R4 as close as possible.
4. 为防止保护功能出错,B,C,D 点的接线应尽量短。
4.To prevent errors of the protection function, the wiring of B, C, and D point should be as short as possible.
5. 在短路保护电路中，R6C6 的时间常数设置在 1.5 ~ 2us 的范围内。由于短路保护时间可能会改变接线方式布局和 R6C6 时间常数的值，因此要对实际系统进行充分的评估。
5.In the short-circuit protection circuit, please select the R6C6 time constant in the range 1.5 ~ 2us. Do enough evaluation on the real system because short-circuit protection time may vary wiring pattern layout and value of the R6C6 time constant.
6. 各个外接电容应尽量靠近 IPM 模块引脚放置。
6.Each capacitor should be mounted as close to the pins of the IPM as possible.
7. 为了防止浪涌损坏，平滑电容 C7 与 P 和 GND 引脚之间的接线应尽可能短。建议在 P 和 GND 引脚之间使用约 0.1 ~ 0.22 F 的高频无感电容。
7.To prevent surge destruction, the wiring between the smoothing capacitor C7 and the P & GND pins should be as short as possible. The use of a high-frequency non-inductive capacitor of around 0.1 ~ 0.22 F between the P & GND pins is recommended.
8. 应采用齐纳二极管或瞬态电压抑制器来保护浪涌对 IC 上每对控制电源端子的破坏。（推荐 20 V / 1 W）。
8.The zener diode or transient voltage suppressor should be adopted for the protection of ICs from the surge destruction between each pair of control supply terminals (Recommended zener diode is 20 V / 1 W).
9. C2 容值建议比自举电容 C3 容值大 7 倍左右。
9.C2 of around 7 times larger than bootstrap capacitor C3 is recommended.
10. V_{FO} 输出脉宽取决于 C_{FOD} 和 COM 之间的电容 C_{FOD} 。
10. V_{FO} output pulse width should be determined by connecting an external capacitor (C_{FOD}) between C_{FOD} (pin 7) and COM.

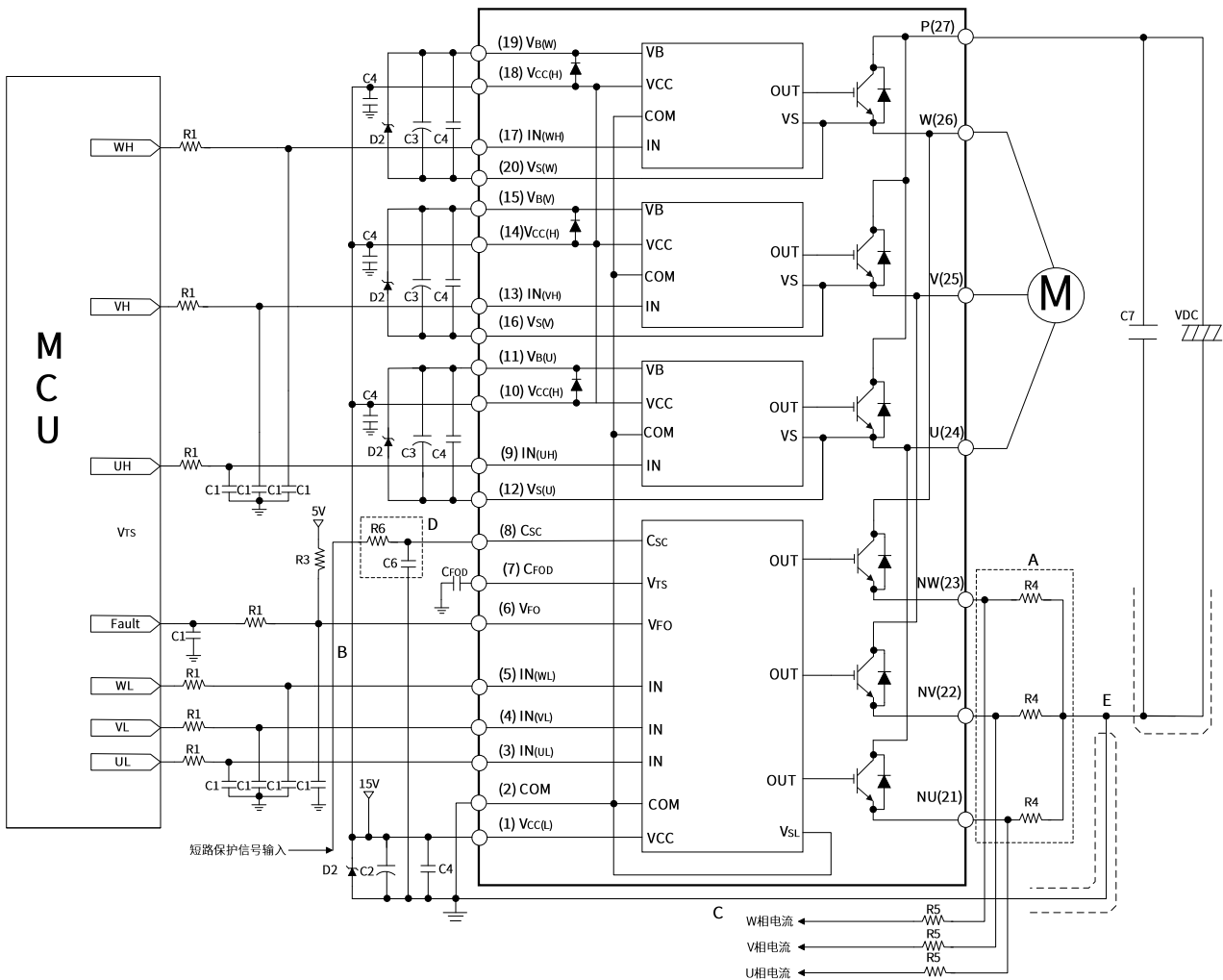
封装外形图/ Package Outline Drawing

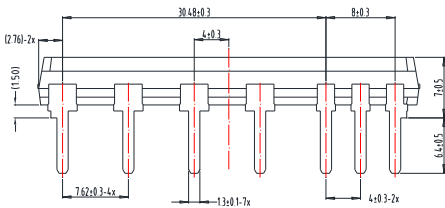
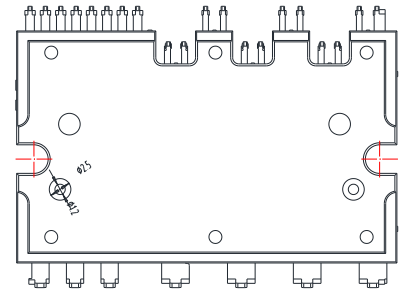
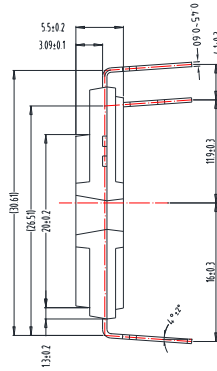
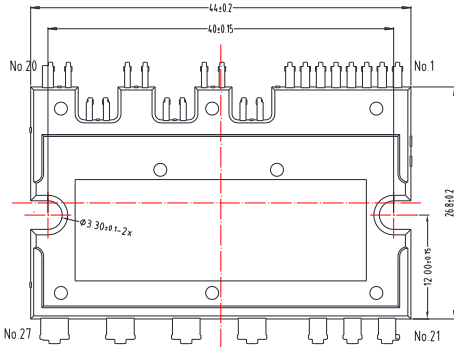
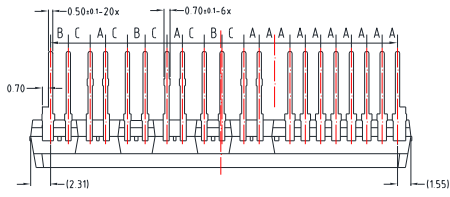

资质等级:工业, 无铅

© 2024 巨风半导体

修订历史 REVISE HISTORY

日期 Date	版本 Version	修订明细 Update detail
2024.06.04	1.0	第一版
2024.06.28	1.1	修改部分参数

重要通知

本文提到的信息，特别是本文所述的案例、提示或任何典型值和/或关于产品应用的一切信息，在任何情况下均不应被视为明示或暗示的保证或授权，包括但不限于基于特定用途的准确性、完整性、适销性、适用性，或不侵犯任何第三方知识产权的担保。

仅使用者本人，应对使用广东巨风半导体有限公司产品或应用，以及安全承担责任。使用者应当遵守与广东巨风半导体有限公司产品或应用程序有关的所有法律、法规和要求，但与产品应用有关的信息和技术支持可能仍由广东巨风半导体有限公司提供。

本文档包含的信息仅供经培训的开发人员，为了对广东巨风半导体有限公司进行产品设计而使用。广东巨风半导体有限公司保留对所提供的产品和服务进行更正、修改、增强、改进或其他变更的权力。广东巨风半导体有限公司仅授权您将些信息用于开发整合广东巨风半导体有限公司产品的相关程序。未经授权，禁止将这些信息用于其他用途，或复制、展示。对上述信息的使用，所产生的任何索赔、损害、费用、损失或责任，广东巨风半导体有限公司不承担任何责任。

警告

由于技术需求，产品可能含有危险物质。

除非广东巨风半导体有限公司在其授权代表签署的书面文件中另行明确，否则广东巨风半导体有限公司的产品不得用于故障产品或可能导致人身损害的情形下。

更多产品、应用和技术信息，请联系广东巨风半导体有限公司(www.tretech.cn)。

广东巨风半导体有限公司

IMPORTANT NOTICE

The information given in this document, especially examples, hints or any typical values stated herein and/or any information regarding the application of the product, shall in no event be regarded as any warranty of authorization of, express of implied, including but not limited to accuracy, completeness, merchantability, fitness for a particular purpose or infringement of any third party's intellectual property rights.

The user is solely responsible for the use of TREX's products and applications, and for the safety thereof. The user shall comply with all laws, regulations and requirements related to TREX's products and applications, although information or support related to any application may still be provided by TREX.

The information is intended only for skilled developers designing with TREX's products. TREX reserves the rights to make corrections, modifications, enhancements, improvements or other changes to the products and services provided. TREX authorizes you to use this information exclusively for the development of relevant applications designed to integrate TREX's products. Using this information for any other purpose, or any unauthorized reproduction or display of these resources is strictly prohibited. TREX Shall not be liable for any claims, damages, costs, losses or liabilities arising out of the use of these resources.

WARNINGS

Due to technical requirements products may contain dangerous substances.

Except as otherwise explicitly approved by TREX Technologies Corporation in a written document signed by authorized representatives of TREX Technologies Corporation, TREX's products may not be used in any applications where a failure of the product or any consequences of the use thereof can reasonably be expected to result in personal injury.

For further information on applications, products and technologies, please contact TREX(www.tretech.cn).

TREX Technologies Corporation